

M se Pitit Bondye,

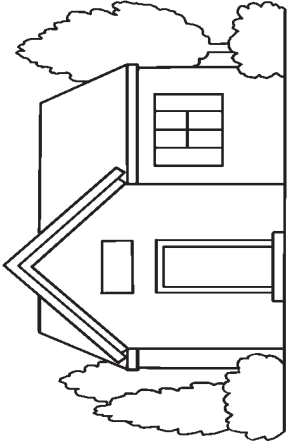

E li voye m isit la,



Li banm yon kay sou tè a

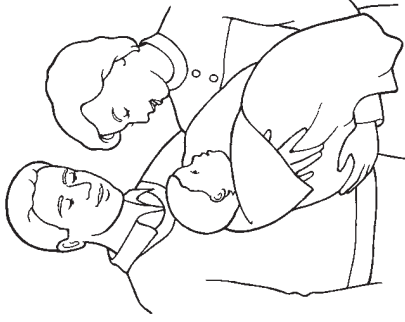

Ak paran ki janti e ki chè pou mwen.

### M se pitit Bondye (Travay 17:22-31)

Koupe de rektang long yo epi tepe yo ansanm pou fè yon papye ki long. Plwaye l sou liy nwa yo tankou yon akòdeyon pou fè yon ti liv.

Tepe la a

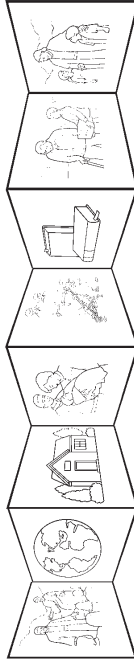

Tepe la a

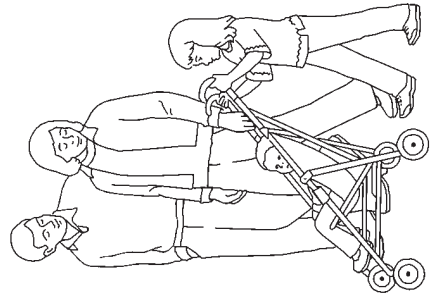

Dirije m, gide m, mache bò kote m,

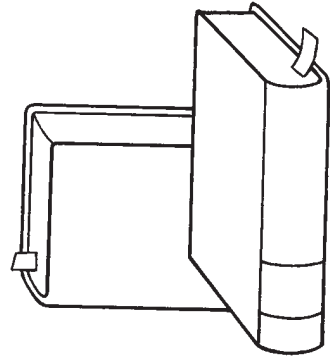

Ede m jwenn wout la.

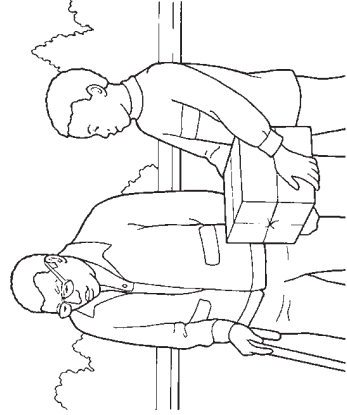

Ansenye m tout sa m dwe fè

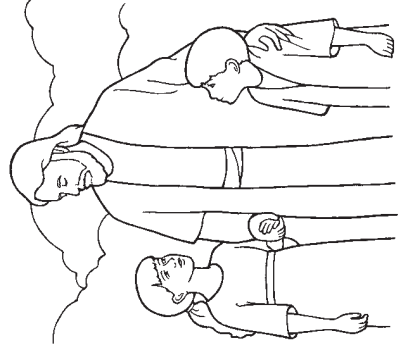

Pou m viv avèk li yon jou.