

**Na vakabauta e lako mai ena rogoci
ni vosa ni Kalou (Roma 10:17).**

Rokataka ka kotiva tani na waqanivola kei
na lima na iyalovalo ni sala eda rogoca kina
na vosa ni Kalou.

Lobika na waqanivola ena laini digo.
ka tepitaka se vakabira vata na yasana lekaleka.
Vakacuruma na iyalovalo ki na waqanivola.

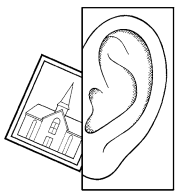
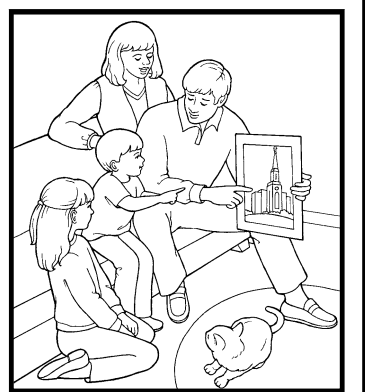
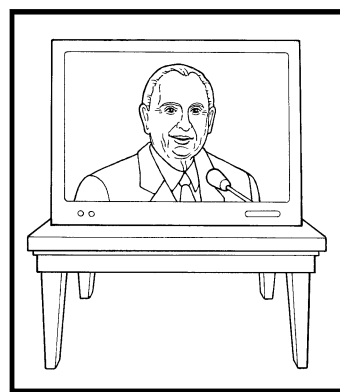
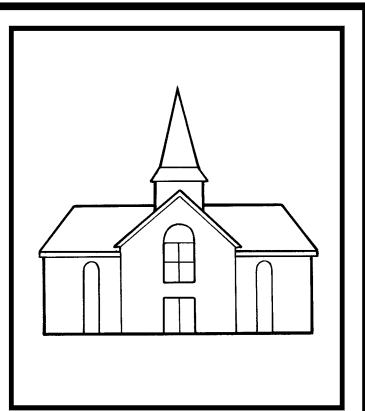
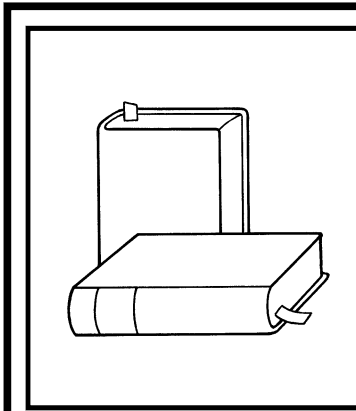

**Na vakabauta
e lako mai ena
rogoci ni vosa
ni Kalou.**

(Roma 10:17)